

FATAL  CMV  SCHOOL BUS  RAILROAD  MAB  SUPPLEMENT  ACTIVE SCHOOL ZONE

Total Num. Units	2	Total Num. Prsns.	2	TxDOT Crash ID
------------------	---	-------------------	---	----------------

Texas Peace Officer's Crash Report (Form CR-3 1/1/2010)

Mail to: Texas Department of Transportation, Crash Records, P.O. Box 149349, Austin, TX 78714. Questions? Call (512) 486-5780  
Refer to Attached Code Sheet for Numbered Fields

\*= These fields are required on all additional sheets submitted for this crash (ex.: additional vehicles, occupants, injured etc.)

IDENTIFICATION AND LOCATION

VEHICLE, DRIVER, & PERSONS

VEHICLE, DRIVER, & PERSONS

\* Crash Date (MM/DD/YYYY) **10 / 24 / 2014** \* Crash Time (24HRMM) **1451** Case ID **2014A002935** Local Use **29D**

\* County Name **DALLAS** \* City Name **GARLAND**  Outside City Limit

In your opinion, did this crash result in at least \$ 1,000 damage to any one person's property?  Yes  No Latitude (decimal degrees) **32.83991** Longitude (decimal degrees) **-96.59562**

**ROAD ON WHICH CRASH OCCURED**  
 \* 1 Rdwy. Sys. **IH** \* Hwy. Num. **30** 2 Rdwy. Part **1** Block Num. **500** 3 Street Prefix **W** \* Street Name **IH 30** 4 Street Suffix **FWY**  
 Crash Occurred on a Private Drive or Road/Private Property/Parking Lot  Toll Road/Toll Lane Speed Limit **60** Const.  Yes  No Workers  Yes  No Street Zone  No Present  No Desc

**INTERSECTING ROAD, OR IF CRASH NOT AT INTERSECTION, NEAREST INTERSECTING ROAD OR REFERENCE MARKER**  
 At  Yes  No 1 Rdwy. Sys. **LR** Hwy. Num. **6100** 2 Rdwy. Part **1** Block Num. **6100** 3 Street Prefix **BROADWAY** Street Name **BROADWAY** 4 Street Suffix **BLVD**

Distance from Int. or Ref. Marker **1**  FT  MI 3 Dir. from Int. or Ref. Marker **E** Reference Marker Street Desc. RRR Num.

Unit Num. **1** 5 Unit Desc. **1**  Parked Vehicle  Hit and Run LP State **TX** LP Num. **CYF5686** VIN **2G1WF5E37C1251964**

Veh. Year **2012** 6 Veh. Color **SIL** Veh. Make **CHEVROLET** Veh. Model **IMPALA** 7 Body Style **P4**  Pol., Fire, EMS on Emergency (Explain in Narrative if checked)

8 DL/ID Type **1** DL/ID State **TX** DL/ID Num. **18756655** 9 DL Class **C** 10 CDL End. **96** 11 DL Rest. **A** DOB (MM/DD/YYYY) **02 / 16 / 1982**

Address (Street, City, State, ZIP) **523 REDWATER RD APT. 1, WAKE VILLAGE, TX 75501**

Person Num	12 Prsn. Type	13 Seat Position	Name: Last, First, Middle Enter Driver Or Primary Person for this Unit on first line	14 Injury Severity	Age	15 Ethnicity	16 Sex	17 Eject.	18 Restr.	19 Airbag	20 Helmet	21 Sol.	22 Alc. Spec.	Alc. Result	23 Drug Spec	24 Drug Result	25 Drug Category
1	1	1	AYERS, AUBREY KENNETH	A	32	W	1	1	1	1	97	N	96		96	97	97
Not Applicable - Alcohol and Drug Results are only reported for Driver/Primary Person for each unit.																	

Owner  Lessee Owner/Lessee name & Address **AYERS, KENNETH JEFFERY 7009 FALL CREEK CT, WATAUGA, TX 76148**

Proof of Fin. Resp.  Yes  No  Expired  Exempt 26 Fin. Resp. Type **2** Fin. Resp. Name **ESURANCE** Fin. Resp. Num. **PATX0041569939**

Fin. Resp. Phone Num. **800-926-1175** 27 Vehicle Damage Rating 1 **-** 27 Vehicle Damage Rating 2 **-** Vehicle Inventoried  Yes  No

Towed By **BIG BASS WRECKER** Towed To **GARLAND AUTO POUND**

Unit Num. **2** 5 Unit Desc. **1**  Parked Vehicle  Hit and Run LP State **UN** LP Num. VIN

Veh. Year **99** 6 Veh. Color **UN** Veh. Make **99** Veh. Model **99** 7 Body Style **99**  Pol., Fire, EMS on Emergency (Explain in Narrative if checked)

8 DL/ID Type **99** DL/ID State **UN** DL/ID Num. **99** 9 DL Class **99** 10 CDL End. **99** 11 DL Rest. **99** DOB (MM/DD/YYYY) **/ /**

Address (Street, City, State, ZIP)

Person Num	12 Prsn. Type	13 Seat Position	Name: Last, First, Middle Enter Driver Or Primary Person for this Unit on first line	14 Injury Severity	Age	15 Ethnicity	16 Sex	17 Eject.	18 Restr.	19 Airbag	20 Helmet	21 Sol.	22 Alc. Spec.	Alc. Result	23 Drug Spec	24 Drug Result	25 Drug Category
1	1	1	UNKNOWN	99	99	99	99	99	99	99	97	N	98		96	97	97
Not Applicable - Alcohol and Drug Results are only reported for Driver/Primary Person for each unit.																	

Owner  Lessee Owner/Lessee name & Address

Proof of Fin. Resp.  Yes  No  Expired  Exempt 26 Fin. Resp. Type **2** Fin. Resp. Name **OTHER** Fin. Resp. Num.

Fin. Resp. Phone Num. **OTHER** 27 Vehicle Damage Rating 1 **-** 27 Vehicle Damage Rating 2 **-** Vehicle Inventoried  Yes  No

Towed By **OTHER** Towed To **OTHER**

DISPOSITION OF INJURED/KILLED	Unit Num.	Prsn. Num.	Taken To	Taken By	Date of Death (MM/DD/YYYY)	Time of Death (24HRMM)
	1	1	BAYLOR OF DALLAS	GARLAND FIRE DEPARTMENT	/ /	
					/ /	
					/ /	
					/ /	
					/ /	

CHARGES	Unit Num.	Prsn. Num.	Charge	Citation/Reference Num.

DAMAGE	Damaged Property Other Than Vehicles	Owner's Name	Owner's Address

CMV	Unit Num.	Weight	Transporting	Capacity	28 Veh. Oper.	29 Carrier ID Type	Carrier ID Num.	
		10,001+ LBS.	HAZARDOUS MATERIAL	9+ CAPACITY				
	Carrier's Corp. Name	Carrier's Primary Addr.						
30 Rdwy. Access	31 Veh. Type	RGVW	HazMat Released	Yes/No	32 HazMat Class Num.	32 HazMat ID Num.	32 HazMat Class Num.	32 HazMat ID Num.
33 Cargo Body Style	Trailer 1 Unit Num.	RGVW	34 Trlr. Type	Trailer 2 Unit Num.	RGVW	34 Trlr. Type		

FACTORS & CONDITIONS	Sequence Of Events	35 Seq. 1	35 Seq. 2	35 Seq. 3	35 Seq. 4	Total Num. Axles	Total Num. Tires

FACTORS & CONDITIONS	36 Contributing factors (Investigator's Opinion)				37 Vehicle Defects (Investigator's Opinion)				Environmental and Roadway Conditions						
	Unit Num.	Contributing	May Have Contrib.		Contributing	May Have Contrib.			38 Weather Cond.	39 Light Cond.	40 Entering Roads	41 Roadway Type	42 Roadway Alignment	43 Surface Condition	44 Traffic Control
	1									1	1	97	3	1	1

NARRATIVE AND DIAGRAM	Investigator's Narrative Opinion of What Happened (Attach Additional Sheets If Necessary)	Indicate North	Field Diagram - Not to Scale
	<p>Officers were dispatched to the 500 blk on W/B IH 30 in reference to a vehicle stopped in the left lane of traffic and the driver slumped over the wheel. Upon arrival officers found Unit 1 stopped over Broadway Blvd in the far left lane with a severe head injury. Officers discovered a hole in the windshield at the rear view mirror. Officers searched the vehicle, for the object which caused the hole, and found what appeared to be a leaf spring from a vehicle lying in the rear floorboard with papers ontop of it. It appears that Unit 1 was travelling W/B and the object came from another vehicle and possibly bounced off the pavement and struck the windshield, penetrating it and striking the driver in the head. Officer also found the sunglasses of the driver with one lens missing while the other lens had scuffmarks indicating that the object struck the driver between the eyes. The driver was transported to Baylor of Dallas Hospital. Officer Orman followed up at the hospital and was able</p>		

INVESTIGATOR	Time Notified (24HRMM)	1 4 5 1	How Notified	DISPATCH	Time Arrived (24HRMM)	1 4 5 7	Report Date (MM/DD/YYYY)	1 0 / 2 7 / 2 0 1 4
	Invest. Comp.	<input checked="" type="checkbox"/> Yes <input type="checkbox"/> No	Investigator Name (Printed)	ORMAN, L R	ID Num.	2250	District/Area	
	ORI Num.	T X 0 5 7 1 1 0 0	* Agency	GARLAND POLICE DEPARTMENT				

Case ID **2014A002935**

TxDOT Crash ID

*Crash Date (MM/DD/YYYY) <b>1 0 / 2 4 / 2 0 1 4</b>	*Crash Time (24HRMM) <b>1 4 5 1</b>	*County Name <b>DALLAS</b>
*City Name <b>GARLAND</b>	*1 Rdwy. Sys. <b>IH</b>	* Hwy. Num. <b>30</b>
*Street Name <b>IH 30</b>		
ORI Num. <b>T X 0 5 7 1 1 0 0</b>	* Agency <b>GARLAND POLICE DEPARTMENT</b>	District/ Area

NARRATIVE CONTINUATION

to get a phone number for the driver`s father before his condition worsened and he became unresponsive. Hospital staff was able to stabilize the driver but still listed in critical condition.

The metal object, possibly a leaf spring, appeared that it had some wear on it but officers are unsure if the object came from the bed of a vehicle or actually dislodged and fell off the vehicle. With the direction of the object showing to come through the center of the windshield and striking the driver in the driver`s seat it appears that the object came from the lanes to the right of Unit 1 which would indicate that it came from a vehicle also going W/B. However there were no witnesses who could verify the evidence at the scene.

WITNESS NAMES:  
HOGAN, BARRY  
(940) 368-5451

Investigator Name (Printed) <b>ORMAN, L R</b>	ID Num. <b>2250</b>	Department <b>GPD</b>	District/ Area
--	------------------------	-----------------------	-------------------

Case ID **2014A002935**

TxDOT Crash ID

\*Crash Date (MM/DD/YYYY) **1 0 / 2 4 / 2 0 1 4**

\*Crash Time (24HRMM) **1 4 5 1**

\*County Name **DALLAS**

\*City Name **GARLAND**

\*1 Rdwy. Sys. **IH**

\*Hwy. Num. **30**

\*Street Name **IH 30**

ORI Num. **T X 0 5 7 1 1 0 0**

\*Agency **GARLAND POLICE DEPARTMENT**

District/ Area

Field Diagram - Not to Scale

Indicate North

DIAGRAM CONTINUATION

500 W. IH 30

West Bound Lanes



East Bound Lanes

Diagram 2

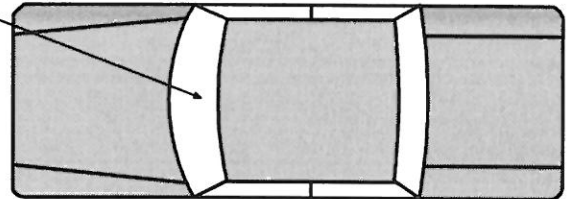

NOT TO SCALE

Investigator Name(Printed)

**ORMAN, L R**

ID Num.

**2250**

Department

**GPD**

District/ Area

Numbered Fields on the CR-3 Refer to the Numbered Lists on this Code Sheet. Each list includes the codes that may be entered on the form and the description of each code.

Law Enforcement and TxDOT Use ONLY.  
Form CR-3CS 1/1/2010

<b>IDENTIFICATION AND LOCATION</b>	<b>1. Roadway System</b> IH = Interstate US = US Highway SH = State Highway FM = Farm to Market RR = Ranch Road RM = Ranch to Market BI = Business Interstate BU = Business US BS = Business State BF = Business FM SL = State Loop TL = Toll Road	<b>2. Roadway Part</b> 1 = Main/Proper Lane 2 = Service/Frontage Road 3 = Entrance/On Ramp 4 = Exit/Off Ramp 5 = Connector/Flyover 98 = Other (Explain in Narrative)	<b>3. Street Prefix, Direction from Int. or Ref. Marker</b> N = North NE = Northeast E = East SE = Southeast S = South SW = Southwest W = West NW = Northwest	<b>4. Street Suffix</b> RD = Road ST = Street DR = Drive AVE = Avenue BLVD = Boulevard PKWY = Parkway LN = Lane FWY = Freeway HWY = Highway WAY = Way TRL = Trail LOOP = Loop	EXPY = Expressway CT = Court CIR = Circle PL = Place PARK = Park CV = Cove
------------------------------------	--	--	---	---	---

<b>5. Unit Description</b> 1 = Motor Vehicle 2 = Train 3 = Pedalcyclist 4 = Pedestrian 5 = Motorized Conveyance 6 = Towed/Trailer 7 = Non-Contact 98 = Other (Explain in Narrative)	<b>6. Vehicle Color</b> BGE = Beige BLK = Black BLU = Blue BRZ = Bronze BRC = Brown CAM = Camouflage CPR = Copper GLD = Gold GRY = Gray GRN = Green MAR = Maroon MUL = Multicolored ONG = Orange PNK = Pink PLE = Purple RED = Red SIL = Silver TAN = Tan TEA = Teal (green) TRQ = Turquoise (blue) WHI = White YEL = Yellow 98 = Other (Explain in Narrative) 99 = Unknown	<b>7. Body Style</b> P2 = Passenger Car, 2-Door P4 = Passenger Car, 4-Door PK = Pickup AM = Ambulance BU = Bus SB = Yellow School Bus FE = Farm Equipment FT = Fire Truck MC = Motorcycle SV = Sport Utility Vehicle PC = Police Car/Truck PM = Police Motorcycle TL = Trailer, Semi-Trailer, or Pole Trailer TR = Truck TT = Truck Tractor VN = Van 98 = Other (Explain in Narrative) 99 = Unknown	<b>8. Driver License/ID Type</b> 1 = Driver License 2 = Commercial Driver Lic. 3 = Occupational 4 = ID Card 5 = Unlicensed 98 = Other 99 = Unknown
---	---	---	---

<b>9. Driver License Class</b> A = Class A AM = Class A and M B = Class B BM = Class B and M C = Class C CM = Class C and M M = Class M 5 = Unlicensed 98 = Other/Out of State 99 = Unknown	<b>10. Commercial Driver License Endorsements</b> H = Hazardous Materials N = Tank Vehicles P = Passengers S = School Bus T = Double/Triple Trailer X = Tank Vehicle with HazMat 5 = Unlicensed 98 = Other/Out of State 99 = Unknown	<b>11. Driver License Restrictions</b> A = With Corrective Lenses B = LOFS Age 21 or Over C = Daytime Only D = Not to Exceed 45 MPH E = No Expressway Driving F = Must Hold Valid Learner Lic. to MM/DD/YY G = TRC 545.424 Applies until MM/DD/YY H = Vehicle Not to Exceed 25,000 lbs GVWR J = Motorcycle Not to Exceed 250 CC K = Licensed Motorcycle Operator Age 21 or Over in Sight L = Vehicle w/o Air Brakes - Applies to Vehicles Requiring CDL M = CDL Intrastate Commerce Only N = Ignition Interlock Required O = Occ./Essent. Need DL-No CMV-See Court Order P = Stated on License Q = LOFS 21 or Over Vehicle Above Class B R = LOFS 21 or Over Vehicle Above Class C S = Outside Rear View Mirror or Hearing Aid T = Automatic Transmission U = Applicable Prosthetic Devices V = Applicable Vehicle Devices W = Power Steering X = Vehicle Not to Exceed Class C Y = Valid TX Vision or Limb Waiver Req'd Z = Valid Fed. Vision or Limb Waiver Req'd 5 = Unlicensed 96 = None 98 = Other/Out of State 99 = Unknown
---	---	--

<b>12. Person Type</b> 1 = Driver 2 = Passenger/Occupant 3 = Pedalcyclist 4 = Pedestrian 5 = Driver of Motorcycle Type Vehicle 6 = Passenger/Occupant on Motorcycle Type Vehicle 98 = Other (Explain in Narrative) 99 = Unknown	<b>13. Seat Position</b> 1 = Front Left 2 = Front Center 3 = Front Right 4 = Second Seat Left 5 = Second Seat Center 6 = Second Seat Right 7 = Third Seat Left 8 = Third Seat Center 9 = Third Seat Right 10 = Cargo Area 11 = Outside Vehicle 13 = Other in Vehicle 14 = Passenger in Bus 16 = Pedestrian, Pedalcyclist, or Motorized Conveyance 98 = Other (Explain in Narrative) 99 = Unknown	<b>14. Injury Severity</b> A = Incapacitating Injury B = Non-Incapacitating Injury C = Possible Injury K = Killed N = Not Injured 99 = Unknown	<b>15. Ethnicity</b> W = White B = Black H = Hispanic A = Asian I = Amer. Indian/Alaskan Native 98 = Other 99 = Unknown	<b>16. Sex</b> 1 = Male 2 = Female 99 = Unknown	<b>17. Ejected</b> 1 = No 2 = Yes 3 = Yes, Partial 97 = Not Applicable 99 = Unknown
---	--	--	--	--	--

<b>18. Restraint Used</b> 1 = Shoulder and Lap Belt 2 = Shoulder Belt Only 3 = Lap Belt Only 4 = Child Seat, Facing Forward 5 = Child Seat, Facing Rear 6 = Child Seat, Unknown 7 = Child Booster Seat 96 = None 97 = Not Applicable 98 = Other (Explain in Narrative) 99 = Unknown	<b>19. Airbag</b> 1 = Not Deployed 2 = Deployed, Front 3 = Deployed, Side 4 = Deployed, Rear 5 = Deployed, Multiple 97 = Not Applicable 99 = Unknown	<b>27. Vehicle Damage Rating</b> In most cases, enter in the format XX-ABC-Y, where XX is the Direction of Force (1-12), ABC is the Damage Description 2- or 3-letter code, and Y is the Damage Severity (0-7).
--	---	--

<b>20. Helmet Use</b> 1 = Not Worn 2 = Worn, Damaged 3 = Worn, Not Damaged 4 = Worn, Unk. Damage 97 = Not Applicable 99 = Unknown if Worn	<b>21. Solicitation</b> Y = Solicit N = No Solicit	<b>22. Alcohol Specimen Type</b> 1 = Breath 2 = Blood 3 = Urine 4 = Refused 96 = None 98 = Other (Explain in Narrative)	<b>25. Drug Category</b> 2 = CNS Depressants 3 = CNS Stimulants 4 = Hallucinogens 6 = Narcotic Analgesics 7 = Inhalants 8 = Cannabis 10 = Disassociative Anesthetics 11 = Multiple Drugs (Explain in Narrative) 97 = Not Applicable 98 = Other Drugs (Explain in Narrative) 99 = Unknown	<b>26. Financial Responsibility Type</b> 1 = Liability Insurance Policy 2 = Proof of Liability Insurance 3 = Insurance Binder 4 = Surety Bond 5 = Certificate of Deposit with Comptroller 6 = Certificate of Deposit with County Judge 7 = Certificate of Self-Insurance
---	--	---	---	---

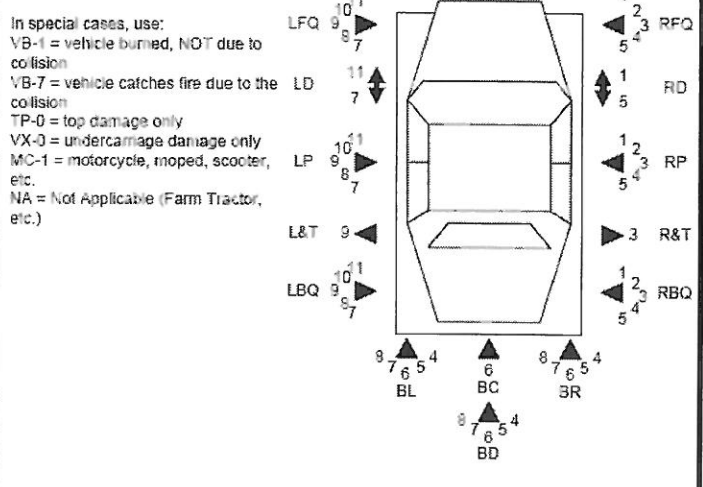

<b>23. Drug Specimen Type</b> 2 = Blood 3 = Urine 4 = Refused 96 = None 98 = Other (Explain in Narrative)	<b>24. Drug Test Result</b> 1 = Positive 2 = Negative 97 = Not Applicable 99 = Unknown
--	--

Numbered Fields on the CR-3 Refer to the Numbered Lists on this Code Sheet. Each list includes the codes that may be entered on the form and the description of each code.

COMMERCIAL MOTOR VEHICLE	<b>28. Vehicle Operation</b> 1 = Interstate Commerce 2 = Intrastate Commerce 3 = Not in Commerce 4 = Government 5 = Personal	<b>29. Carrier ID Type</b> 1 = US DOT 2 = TxDOT 3 = ICC/MC 56 = None 98 = Other (Explain in Narrative)	<b>30. Roadway Access</b> 1 = Full Access Control 2 = Partial Access Control 3 = No Access Control	<b>31. Vehicle Type</b> 1 = Passenger Car 2 = Light Truck 3 = Bus (9-15) 4 = Bus (>15) 5 = Single Unit Truck 2 Axles 6 Tires 6 = Single Unit Truck 3 or More Axles 7 = Truck Trailer 8 = Truck Tractor (Sobtail) 9 = Tractor/Semi Trailer 10 = Tractor/Double Trailer 11 = Tractor/Triple Trailer 98 = Other (Explain in Narrative) 99 = Unknown Heavy Truck	<b>32. Hazardous Material Class Number</b> 1 = Explosives 2 = Gases 3 = Flammable Liquids 4 = Flammable Solids 5 = Oxidizers and Organic Peroxides 6 = Toxic Materials and Infectious Substances 7 = Radioactive Materials 8 = Corrosive Materials 9 = Miscellaneous Dangerous Goods
	<b>33. Cargo Body Style</b> 1 = Bus (9-15) 2 = Bus (>15) 3 = Van/Enclosed Box 4 = Cargo Tank 5 = Flatbed 6 = Dump 7 = Concrete Mixer	8 = Auto Transporter 9 = Garbage Refuse 10 = Grain Chipp Gravel 11 = Pole 13 = Intermodal 14 = Logging	15 = Vehicle Towing Another Vehicle 97 = Not Applicable 98 = Other (Explain in Narrative)	<b>34. Trailer Type</b> 1 = Full Trailer 2 = Semi-Trailer 3 = Pole Trailer	
FACTORS AND CONDITIONS	<b>35. Sequence of Events</b> 1 = Non-Collision: Ran Off Road 2 = Non-Collision: Jackknife 3 = Non-Collision: Overtum Rollover 4 = Non-Collision: Downhill Runaway 5 = Non-Collision: Cargo Loss Or Shift 6 = Non-Collision: Explosion Or Fire 7 = Non-Collision: Separation of Units 8 = Non-Collision: Cross Median/Centerline 9 = Non-Collision: Equipment Failure 10 = Non-Collision: Other 11 = Non-Collision: Unknown 12 = Collision Involving Pedestrian 13 = Collision Involving Motor Vehicle in Transport 14 = Collision Involving Parked Motor Vehicle 15 = Collision Involving Train 16 = Collision Involving Pedalcycle 17 = Collision Involving Animal 18 = Collision Involving Fixed Object 19 = Collision With Work Zone Maintenance Equipment 20 = Collision With Other Movable Object 21 = Collision With Unknown Movable Object 98 = Other (Explain in Narrative)				
	<b>36. Factors and Conditions</b> 1 = Animal on Road - Domestic 2 = Animal on Road - Wild 3 = Backed without Safety 4 = Changed Lane when Unsafe 14 = Disabled in Traffic Lane 15 = Disregard Stop and Go Signal 16 = Disregard Stop Sign or Light 17 = Disregard Turn Marks at Intersection 18 = Disregard Warning Sign at Construction 19 = Distraction in Vehicle 20 = Driver Inattention 21 = Drove Without Headlights 22 = Failed to Control Speed 23 = Failed to Drive in Single Lane 24 = Failed to Give Half of Roadway 25 = Failed to Heed Warning Sign 26 = Failed to Pass to Left Safely 27 = Failed to Pass to Right Safely 28 = Failed to Signal or Gave Wrong Signal 29 = Failed to Stop at Proper Place 30 = Failed to Stop for School Bus 31 = Failed to Stop for Train 32 = Failed to Yield ROW – Emergency Vehicle 33 = Failed to Yield ROW – Open Intersection 34 = Failed to Yield ROW – Private Drive 35 = Failed to Yield ROW – Stop Sign 36 = Failed to Yield ROW – To Pedestrian 37 = Failed to Yield ROW – Turning Left 38 = Failed to Yield ROW – Turn on Red 39 = Failed to Yield ROW – Yield Sign 40 = Fatigued or Asleep 41 = Faulty Evasive Action 42 = Fire in Vehicle 43 = Fleeing or Evading Police 44 = Followed Too Closely 45 = Had Been Drinking 46 = Handicapped Driver (Explain in Narrative) 47 = Hill (Explain in Narrative) 48 = Impaired Visibility (Explain in Narrative) 49 = Improper Start from Parked Position 50 = Load Not Secured 51 = Opened Door Into Traffic Lane 52 = Oversized Vehicle or Load 53 = Overtake and Pass Insufficient Clearance 54 = Parked and Failed to Set Brakes 55 = Parked in Traffic Lane 56 = Parked without Lights 57 = Passed in No Passing Lane 58 = Passed on Right Shoulder 59 = Pedestrian FTYROW to Vehicle 60 = Unsafe Speed 61 = Speeding – (Over Limit) 62 = Taking Medication (Explain in Narrative) 63 = Turned Improperly – Cut Corner on Left 64 = Turned Improperly – Wide Right 65 = Turned Improperly – Wrong Lane 66 = Turned when Unsafe 67 = Under Influence – Alcohol 68 = Under Influence – Drug 69 = Wrong Side – Approach or Intersection 70 = Wrong Side – Not Passing 71 = Wrong Way – One Way Road 72 = Cell/Mobile Phone Use 73 = Road Rage 98 = Other (Explain in Narrative)				
	<b>37. Vehicle Defects</b> 5 = Defective or No Headlamps 6 = Defective or No Stop Lamps 7 = Defective or No Tail Lamps 8 = Defective or No Turn Signal Lamps 9 = Defective or No Trailer Brakes 10 = Defective or No Vehicle Brakes 11 = Defective Steering Mechanism 12 = Defective or Slick Tires 13 = Defective Trailer Hitch 98 = Other (Explain in Narrative)	<b>38. Weather Condition</b> 1 = Clear 2 = Cloudy 3 = Rain 4 = Sleet/Hail 5 = Snow 6 = Fog 7 = Blowing Sand/Snow 8 = Severe Crosswinds 98 = Other (Explain in Narrative) 99 = Unknown	<b>39. Light Condition</b> 1 = Daylight 2 = Dark, Not Lighted 3 = Dark, Lighted 4 = Dark, Unknown Lighting 5 = Dawn 6 = Dusk 98 = Other (Explain in Narrative) 99 = Unknown	<b>40. Entering Roads</b> 2 = Three Entering Roads – T 3 = Three Entering Roads – Y 4 = Four Entering Roads 5 = Five Entering Roads 6 = Six Entering Roads 7 = Traffic Circle 8 = Cloverleaf 97 = Not Applicable 98 = Other (Explain in Narrative)	
	<b>41. Roadway Type</b> 1 = Two-Way, Not Divided 2 = Two-Way, Divided, Unprotected Median 3 = Two-Way, Divided, Protected Median 4 = One-Way 98 = Other (Explain in Narrative)	<b>42. Roadway Alignment</b> 1 = Straight, Level 2 = Straight, Grade 3 = Straight, Hillcrest 4 = Curve, Level 5 = Curve, Grade 6 = Curve, Hillcrest 98 = Other (Explain in Narrative) 99 = Unknown	<b>43. Surface Condition</b> 1 = Dry 2 = Wet 3 = Standing Water 4 = Snow 5 = Slush 6 = Ice 7 = Sand, Mud, Dirt 98 = Other (Explain in Narrative) 99 = Unknown	<b>44. Traffic Control</b> 2 = Inoperative (Explain in Narrative) 3 = Officer 4 = Flagman 5 = Signal Light 6 = Flashing Red Light 7 = Flashing Yellow Light 8 = Stop Sign 9 = Yield Sign 10 = Warning Sign 11 = Center Stripe/Divider 12 = No Passing Zone 13 = RR Gate/Signal 14 = Crosswalk 15 = Bike Lane 16 = Marked Lanes 17 = Signal Light With Red Light Running Camera 18 = Signal Light With Red Light Running Camera 96 = None 98 = Other (Explain in Narrative)	